



LiFeBATT, Inc.

Product Specification

Model No.: 2295120F1

Doc. No.:CS10301

Rev: D1.0

Page: 1 of 5

1. Preface

The product specification covers the general performance, test method and quality requirements for the rechargeable lithium ion battery, 2295120F1, manufactured and supplied by LiFeBATT, Inc.

2. Description

2.1	Description	Rechargeable Lithium-ion Ferrous Phosphate Battery
2.2	Dimension	22 mm (T) × 95 mm (W) × 120 mm (H)
2.3	Weight	Approx. 495±10 g

3. Specifications

3.1	Nominal Capacity	20,000mAh
3.2	Minimum Capacity	19500mAh
3.3	Charging Voltage	3.65 V
3.4	Typical Voltage	3.20 V
3.5	Cut-off Discharge Voltage	2.30 V
3.6	Charging Method	CC/CV (Constant Current/Constant Voltage)
3.7	Maximum Discharge Current (continuous)	100A
	Maximum Discharge Current (18s pulse)	260 A
3.8	Maximum Charge Current	40A
3.9	Cycle Life (minimum)	1500 cycles 16000mAh
3.10	Operation Temperature	
	Charge Temperature Range	-10~50
	Discharge Temperature Range	-20~55
3.11	Short Period (1 month)	0~45
	Long Period (6 month)	0~35
3.12	Energy Density	
	Gravimetric	> 129 Wh/Kg
	Volumetric	> 255Wh/L
3.13	Power Density (80% SOC, 18s peak)	
	Gravimetric	> 1100 W/Kg
	Volumetric	> 2200 W/L
3.14	Initial Internal Impedance	< 6 mΩ

4. Outline Dimension



LiFeBATT, Inc.

Product Specification

Model No.: 2295120F1

Doc. No.:CS10301

Rev: D1.0

Page: 2 of 5

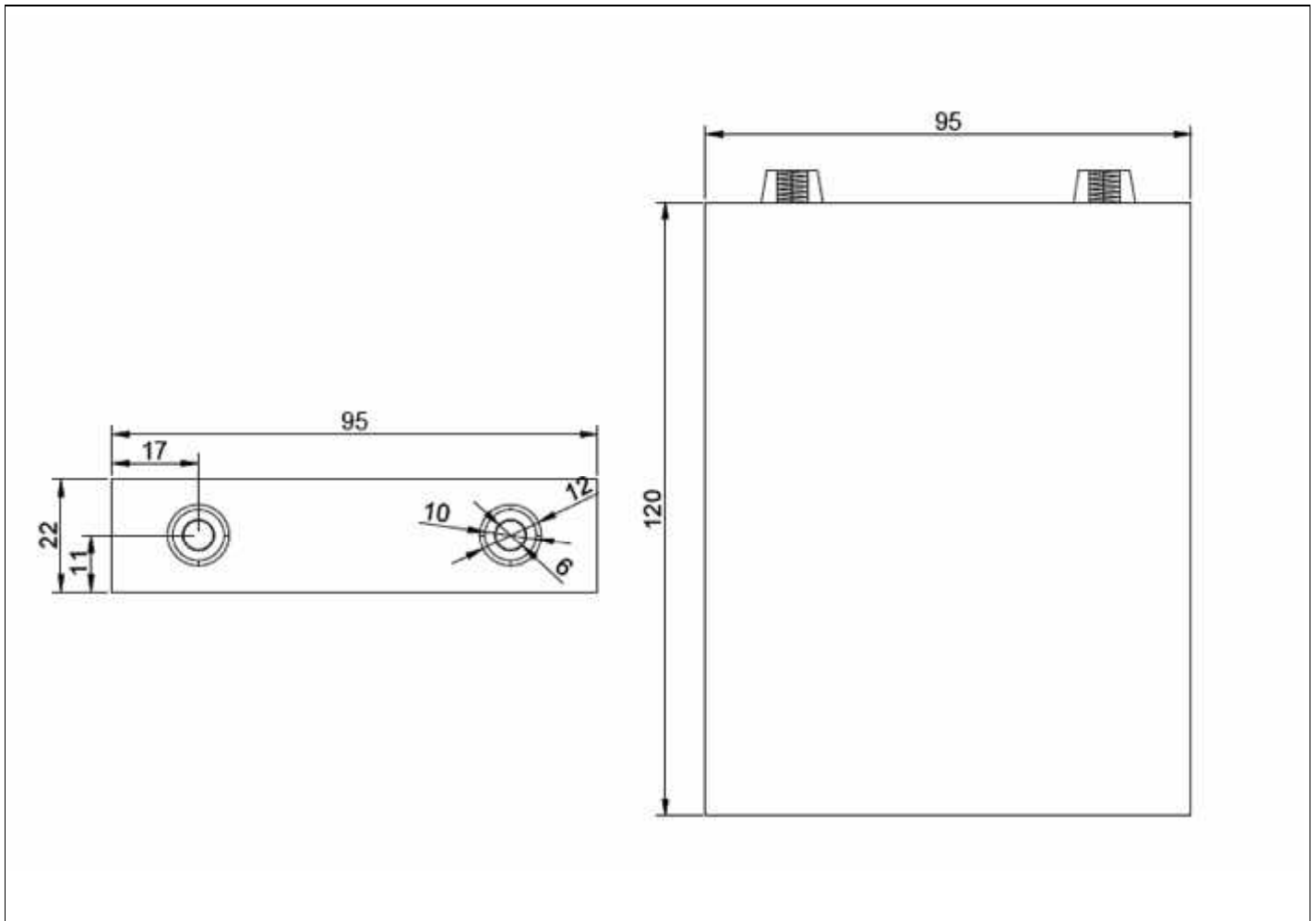

5. Appearance

Appearance shall be free from any remarkable scratches, flaws, rust, discoloration or electrolyte leakage

6. Standard Test Conditions

6.1 Environmental Conditions

Unless otherwise specified, all tests stated in this Product Specification are conducted within the temperature range of 23 ± 3 and the humidity range of $50\pm 20\%RH$.

6.2 Test Equipment

6.2.1 Charger and voltmeter

The charger and voltmeter should have an accuracy of $\pm 0.01A$ and $\pm 0.01V$.

6.2.2 Slide Caliper

The slide caliper should have a scale of 0.05mm



6.2.3 Impedance meter

The impedance meter should be operated at 1kHz.

7. Reliability Test Procedure and Criteria

Item	Test Procedure	Criteria	
7.1	Appearance	Visual	No Defect and Leakage
7.2	Dimension	Caliper	As item 4
7.3	Weight	Scale	As item 2.3
7.4	Fully Charged	CC/CV (Constant Current / Constant Voltage)	Constant Current 20 A Constant Voltage: 3.65 V
7.5	Open Circuit Voltage (as shipment)	Voltmeter	3250 ~3350 mV
7.6	Internal Impedance	Impedance meter at 1kHz AC	<3 mΩ
7.7	Discharge Capacity	After fully charged, discharge at 0.2C current until the voltage reaches 2.3V.	>19500 mAh
7.8	Cycle Life	Charge: CC/CV, CC at 0.2C, CV at 3.65 V, Cut-off Current: 0.05C. Discharge: 0.2C to 2.3V.	The 1500 th Discharge capacity 16000 mAh

8. Safety Test Procedure and Criteria

Item	Test Method	Criteria	
8.1	Short Circuit	At room temperature, connecting the positive and negative terminals of the cell with a maximum resistance load of 0.1 ohm until it is completely discharged and the cell's temperature has returned to near ambient temp.	No fire or explosion. The temperature of the exterior cell shall below 150
8.2	Abnormal Charge	The cell is to be subjected to a 0.2C charging current and charged to 5.0V (CC/CV) for 7 hours at RT	No fire or explosion



LiFeBATT, Inc.

Product Specification

Model No.: 2295120F1

Doc. No.:CS10301

Rev: D1.0

Page: 4 of 5

8.3	Crush	Place the cell between 2 iron plates in parallel. Apply a force of 13 kN on the plate by a 32mm diameter piston. Both the wide and narrow sides are subjected to the crush. Separate samples are to be used for each test.	No fire or explosion
8.4	Impact	Place the cell on a flat surface. Put a $\Phi 15.8\text{mm}$ bar across the center of the sample. Drop a 9.1Kg weight from a height of $610\pm 25\text{mm}$ onto the sample. Both the wide and narrow sides are subjected to the impact. Separate samples are to be used for each test.	No fire or explosion
8.5	Shock	For each shock the cell is to be accelerated during the initial 3 milliseconds the minimum average acceleration is 75 G. The peak acceleration is between 125 and 175G. Each cell shall be applied in a total of three shocks of equal magnitude and in each of three mutually perpendicular directions.	No fire, explosion, vent or leak
8.6	Vibration	The cell is to be subjected to simple harmonic motion with amplitude of 0.8 mm (1.6mm total excursion). The frequency is to be varied between 10 and 55 Hz at the rate of $1\pm 0.055\text{Hz/min}$, and return in not less than 90 or more than 100 min. The cell is to be tested in	No fire, explosion, vent or leak



LiFeBATT, Inc.

Product Specification

Model No.: 2295120F1

Doc. No.:CS10301

Rev: D1.0

Page: 5 of 5

		three mutually perpendicular directions.	
8.7	Drop	The cell is to be dropped 10 times from a height of 1.9m onto a hard wood floor. Each plane (direction) shall be tested at least 1 times.	No fire, explosion or vent
8.8	Heating	Put cell into oven. The temperature of the oven is to be raised at a rate of 5 ± 2 /min to a temperature of 150 ± 2 and remain for 10 minutes at the temperature.	No fire or explosion

9.Shipping

The state of charge while battery at shipping is 90 ± 10 % of full capacity.

10. Manufacture code

The manufacture code (lot number, month, and year) shall be indicated on the battery.

11. Storage for a long time

1. If the battery will be stored for a long time (longer than 1 months), it is better to preserve the battery at the environment of low humidity and low temperature.
2. Use within 3 months (90days) after shipping

**CELLS MADE IN TAIWAN – NOT IN CHINA
BATTERY PACKS MADE IN USA.**

SEE DISCHARGE CURVE LAST PAGE



LiFeBATT, Inc.

Product Specification

Model No.: 2295120F1

Doc. No.:CS10301

Rev: D1.0

Page: 6 of 5

